

Front Bumper and Header

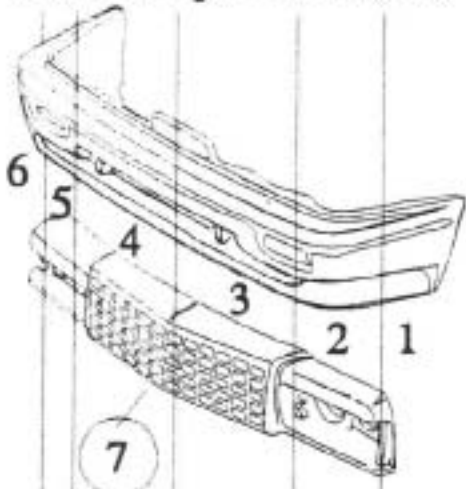

# ARA

## Damage™ Locator

Bumpers and End Panels only use #1 and #6 when they wrap around the side

Rear Bumper and End Panel

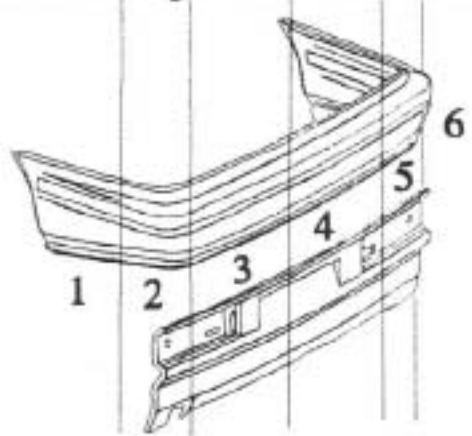

Fender

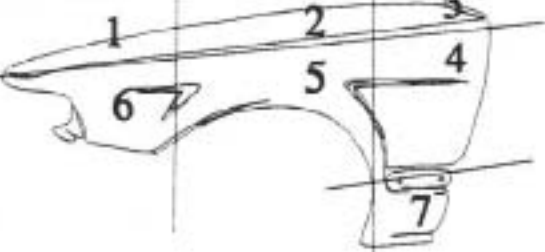

2-Dr Quarter

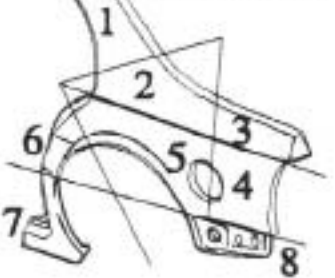

4-Dr Quarter



Deck Lid

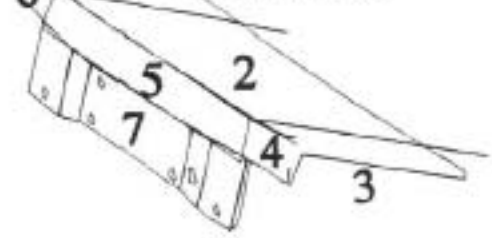

Hood

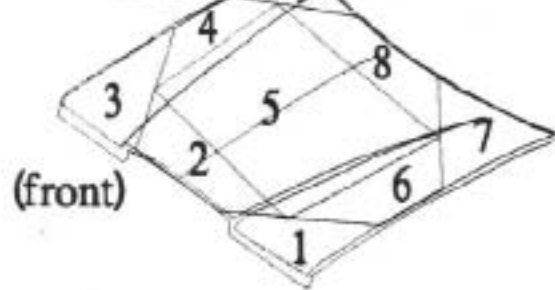

Tail Gate

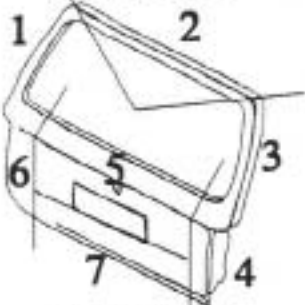

Hatch

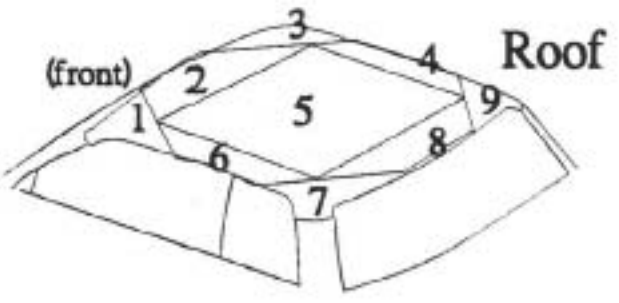
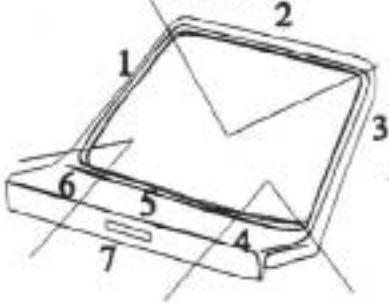

Dotted Lines in Window Area for Gates with Windows

Front Door

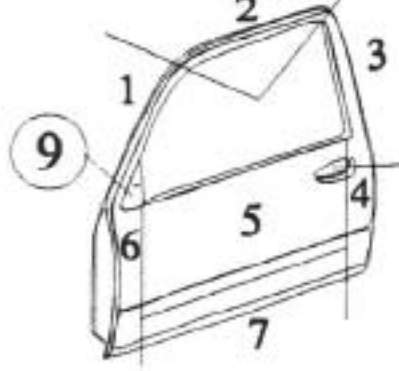

Rear Split Door



Rear Door

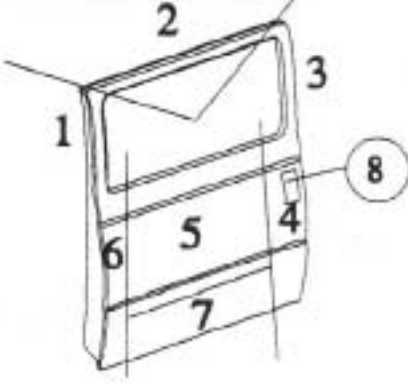

Back Door

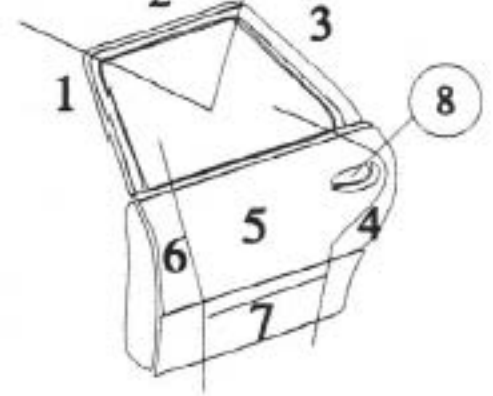

Damage Locations always follow the same pattern: Front to back, top to bottom, left to right (as seen from driver's seat), in an "S" pattern, with locations for door handles and mirrors. Codes are location, damage, and hours. Example: "2DI" is a one hour dent in location 2. There may be a primary and secondary code per part, as in "2DI,4S2". If there is no damage on a part the code is 000 (as in three zeros). Zero as a location indicates the entire panel, as in 0H4 (all over hail damage, 4 Hrs).

### Damage Code Table

B = Burn	C = Crease	R = Rust on Surface
D = Dent	E = Bent	P = Parking Lot Dings
L = Lip	K = Buckle	S = Scratch - Surface Only
H = Hail	J = Rip or crack	T = Paint Problem
000 = No Damage (all zero)		